

31000 and 32000 Proximity Probe Housing Assemblies

Datasheet

Bently Nevada Machinery Condition Monitoring

141610 Rev. L

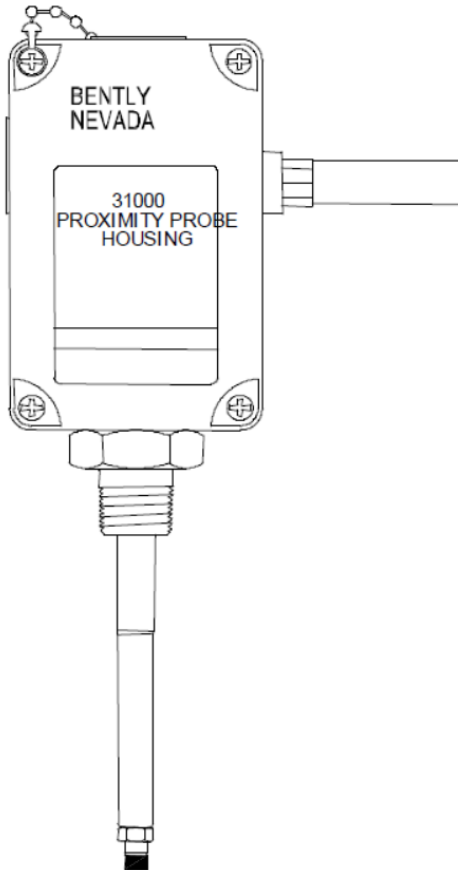

Description

The 31000/32000 Proximity Probe Housing Assemblies are recommended when mounting proximity probes through the machine case and are typically used for radially mounted transducers, whether vibration or Keyphasor measurements.



When using these housings to measure radial vibration, ensure that the machine casing is affixed to the bearing in order to get an accurate relative vibration signal.



When measuring shaft axial position with dual proximity probes, use housing 21022 instead. Consult datasheet (document 141601).

Use of a Proximity probe housing allows external access to the proximity probe and its extension cable, permitting gap adjustment or probe replacement without disassembly of the machine. The 31000/32000 Proximity Probe Housing Assembly is made of polyphenylene sulfide (PPS), an advanced, high-strength, thermoplastic with excellent corrosion resistance. Other elements of the housing assembly are made of corrosion-resistant stainless steel. The housing can be ordered with installed 3300 XL Proximity Probes and a variety of conduit fittings.

The 31000/32000 Proximity Probe Housing Assembly is fully compliant with the American Petroleum Institute's (API) 670 Standard for externally mounted proximity probe housings.

When installed in conjunction with an approved transducer system and appropriate I.S. barriers, the 31000/32000

Proximity Probe Housing Assembly can be used in intrinsically safe hazardous area applications.



The 31000/32000 Housing is intended to provide mechanical and environmental protection only, and is not an explosion-proof housing. When an explosion proof proximity probe housing assembly is required, use housing CA21000 or CA24701. Consult the datasheet (document 141600).

Related Documents

For probe information, refer to the following manuals:

- *3300 XL 8mm & 3300 5mm Proximity Transducer System User Guide* (document 141078)
- *3300 XL NSv Proximity Transducer System User Guide* (document 147357)
- *3300 XL 11mm Proximity Transducer System Installation User Guide* (document 146255)
- *Radiation Resistant Probe and Proximitor System* (document TW8029407)

Specifications

Environmental

3300 XL 8 mm Probe

Operating and storage	-51 °C to +177 °C (-60 °F to +351 °F)
-----------------------	---------------------------------------

3300 XL 11 mm Probe

Operating and storage	-51 °C to +177 °C (-60 °F to +351 °F)
-----------------------	---------------------------------------

3300 NSV Probe

Operating	-34 °C to +177 °C (-30 °F to +351 °F)
-----------	---------------------------------------

Storage	-51 °C to +177 °C (-60 °F to +351 °F)
---------	---------------------------------------

Hot Water and Steam Exposure Effects

 (Specification not guaranteed). Brief periods (up to one week) of contact with hot water (95°C [203°F]) and/or condensing steam should not significantly affect the strength of the plastic housing. Contact with these beyond this length of time may eventually cause the strength of the plastic housing to permanently decrease during the first 6 to 8 weeks of exposure, and then level at approximately half of its initial value. Tests of actual housing performance after contact with hot water and condensing steam have not been conducted.

Probe Pressure

The 31000/32000 Proximity Probe Housing Assembly is designed to seal differential pressure between the probe tip and the housing main body when used with a 3300 XL 8 mm probe. The sealing material internal to the probe case consists of a Viton O-ring; the O-ring between the sleeve and the housing is a Neoprene O-ring. The plastic housing is certified

to seal against hose-directed water according to NEMA 4X and IP66 standards but is not designed to resist internal or external pressure. Probes are not pressure tested prior to shipment. Contact our custom design department if you require a test of the pressure seal for your application.



It is the responsibility of the customer or user to ensure that all liquids and gases are contained and safely controlled should leakage occur from a Proximity Probe Housing Assembly. Solutions with high or low pH values may erode the tip assembly of the probe, causing media leakage into surrounding areas. Bently Nevada, LLC, does not be held responsible for any damages resulting from leaking Proximity Probe Housing Assemblies. In addition, Proximity Probe Housing Assemblies and 3300 XL 8 mm proximity probes does not be replaced under the service plan due to probe leakage.

Mechanical

Protection Ratings	Type 4X rating certified by Canadian Standards Association (CSA). IP66 rating verified by SC115582-1 (e) 106. CENELEC standard EN50014 rating for electrostatic dissipation of a plastic material located in a hazardous area.
Housing Material	Glass-reinforced Polyphenylene Sulfide (PPS) thermoplastic containing conductive fibers
Sleeve Material and Retaining Chain	AISI 304 stainless steel
Outer Sleeve and Exterior Screws	AISI 303 stainless steel

O-Ring Material	Neoprene
Recommended Torque (retaining nut)	29.4 N·m (260 in·lb)
Housing Strength (typical)	Outer sleeve was mounted on a test stand with its axis parallel to horizontal and the housing mounted on the outer sleeve through an end hole. The housing supported 912 N (205 lb) placed approximately 38 mm (1.5 inches) from the unsupported end with the cover fastened in place and grounding liner installed.
Housing Impact Strength	Certified by BASEEFA to withstand two separate 4 Joule (3.0 ft·lb) impacts at -39°C (-38°F) and at 115 °C (239°F). Samples of the housing and cover were verified by CSA to withstand a 7 Joule (5.2 ft·lb) impact at ambient room temperature.
Weight	1.2 kg (2.6 lb) typical

Compliance and Certifications

Hazardous Area Approvals



For the detailed listing of country and product specific approvals, refer to the *Approvals Quick Reference Guide* (108M1756) available from Bently.com.

21000 and 24701

CA housings are certified by CSA for explosion - proof applications in the following areas:

North America	Class 1 Divisions 1 and 2 Groups C and D Class 2 Divisions 1 and 2 Groups E, F and G Circuit is non-incendive when connected per drawing 140979 Class III Enclosure Type 4 T5 @ Ta = -50 °C to +40 °C T4 @ Ta = -50 °C to +80 °C
---------------	--

Ordering Information



For the detailed listing of country and product specific approvals, refer to the *Approvals Quick Reference Guide* (108M1756) available from Bently.com.

Table 1: Maximum "C" Option plus "D" Option for different "B" Options (probe cable length)

Probe Cable Length	Maximum C plus D
0.5 meter	394 mm (15.5 in)
1.0 meter	760 mm (30.0 in)

Table 2: Maximum "C" Option plus "D" Option for different "B" Options (probe cable length) where P/N and S/N Label on Probe Cable is visible outside of probe sleeve

Probe Cable Length	Maximum C plus D with Visible P/N and S/N Label
0.5 meter	64 mm (2.5 in)
1.0 meter	483 mm (19.0 in)



Conduit fittings are necessary when hardline conduit or metal tubing is brought into the housing. Flexible conduit should be ordered with integral 3/4-14 NPT fittings and do not require additional conduit fittings with the housing. If using flexible conduit, order the "E" = 00 option.

English Proximity Probe Housing Assemblies

31000 - AA-BB-CC-DDD-EE-FF

A: Probe with Connector

00	Probe not required
16	3300 XL 8 mm probe
26	3300 XL NSv probe
27	3300 XL NSv probe, multiple approvals
28	3300 XL 8 mm probe, multiple approvals
29	3300 XL 8 mm probe, with connector protector
30	3300 XL 8 mm probe, with connector protector, multiple approvals
31	3300 XL NSv probe with connector protector
32	3300 XL NSv probe with connector protector, multiple approvals
33	3300 XL 11 mm probe
34	3300 XL 11 mm probe, multiple approvals
35	3300 XL 11 mm probe with connector protector
36	3300 XL 11 mm probe with connector protector, multiple approvals

B: Probe Cable Length

00	Probe cable not required
05	0.5 m (20 in)
10	1.0 m (39 in)

C: Standoff Adapter Length (Option C Dimension)

	 Must be ordered if Standoff Adapter Length option is not 00.
15	Minimum length 1.5 in (38 mm)
75	Maximum length 7.5 in (191 mm)
	Recommendation Order in increments of 0.5 in (13 mm)
	Examples 1.5 in (38 mm) = 15 No standoff adapter = 00

D: Probe Penetration Option (Option D Dimension)

10	Minimum length 1.0 in (25.4 mm)
	Recommendation Order in increments of 0.1 in (3 mm)
	Examples No probe sleeve = 000 3.7 in (94 mm) = 037 2.4 in (569 mm) = 224

 "C" plus "D" dimensions greater than 12 in (305 mm) require additional sleeve support near the probe to prevent resonance from occurring. Sleeve adjustment range of Probe Penetration Option "D" is ± 0.5 in (13 mm).

For probe penetration lengths between 1.0 and 2.0 inches, it may be necessary to counter bore the machine case to reduce probe side view or rear view effects.

E: Fittings

00	Without fittings
01	One 3/4-14 NPT fitting, two plugs.
02	Two 3/4-14 NPT fittings, one plug.

03	Two plugs, one 3/4-14 NPT fitting One 3/4-14 to 1/2-14 NPT SST reducer One cable seal grip with grommets for the following cable sizes: • 1/8 to 3/16 inches • 1/4 to 5/16 inches • 5/16 to 3/8 inches
06	One 3/4-14 NPT fitting One 3/4-14 NPT to 1/2-14 NPR SST reducer Two plugs
F: Mounting Thread Option	
00	No outer sleeve, retainer, or retaining nut
02	3/4-14 NPT (Required if ordering Standoff Adapter Option).
05	7/8-14 UNF 2A

Metric Proximity Probe Housing Assemblies

32000 - AA-BB-CC-DDD-EE-FF

A: Probe with Connector

00	Probe not required
16	3300 XL 8 mm probe
26	3300 XL NSv probe
27	3300 XL NSv probe, multiple approvals
28	3300 XL 8 mm probe, multiple approvals
29	3300 XL 8 mm probe, with connector protector
30	3300 XL 8 mm probe, with connector protector, multiple approvals
31	3300 XL NSv probe with connector protector
32	3300 XL NSv probe with connector protector, multiple approvals
33	3300 XL 11 mm probe
34	3300 XL 11 mm probe, multiple approvals
35	3300 XL 11 mm probe with connector protector
36	3300 XL 11 mm probe with connector protector, multiple approvals

B: Probe Cable Length

00	Probe cable not required (Option A must also be 00)
05	0.5 m (20 in)
10	1.0 m (39 in)

C: Standoff Adapter Length (Option C Dimension)



Must be ordered if Standoff Adapter Length option is not 00.

04	Minimum length 40 mm
20	Maximum length 200 mm
	Recommendation Order in increments of 10 mm

D: Probe Penetration Option (Option D Dimension)

760	Maximum length 760 mm
025	Minimum length 25 mm
	Recommendation Order in increments of 1.0 mm
	Examples No probe sleeve = 000 50 mm = 050 760 mm = 760



"C" plus "D" dimensions greater than 12 in (305 mm) require additional sleeve support near the probe to prevent resonance from occurring. Sleeve adjustment range of Probe Penetration Option "D" is ±0.5 in (13 mm).

For probe penetration lengths between 25 and 50 millimeters, it may be necessary to counter bore the machine case to reduce probe side view or rear view effects.

E: Fittings

00	Without fittings; two plugs and two washers.
01	One M25 fitting, two plugs.
02	Two M25 fittings, one plug.

03	Two plugs, one M20 fitting One cable seal grip with grommets for armored probe cable
05	One DIN PG11 fitting, two plugs
07	One PG21 x M20 fitting Two plugs
08	Two PG21 x M20 fittings One plug

F: Mounting Thread Option

00	No outer sleeve, retainer, or retaining nut
01	M24 X 3
02	3/4-14 NPT (Required if ordering Standoff Adapter Option.)

Terminal Housing

106769-AA

The 106769 housing consists of a 31000-style PPS housing with two terminal mounting blocks (each terminal block has four terminals) mounted in each housing. Sixteen ring lugs are supplied loose inside the housing for connecting transducer cables. Conduit fittings are 3/4-14 NPT chrome-plated zinc fittings.

A: Conduit Fitting Option

00	No fittings
01	One fitting
02	Two fittings

Accessories

Part Number	Description
37948-01	Probe Support / Oil Seal Recommended for sleeves longer than 305 mm (12 in)
124200	31000 and 32000 User Guide

English Probe Sleeve for 31000 Proximity Probe Housings 108883-AAA

A: Measured Probe Sleeve Length

Recommendation
Order in increments of 0.1 in (3 mm)

The individual probe sleeve length does **not** include the distance from the end of the sleeve to the probe tip or the gap from the probe tip to the target material. If only the part number of the original housing is known, and the sleeve cannot be measured, use the following table to determine the sleeve length:

AAA Option for 31000 Prox Probe Housing	Description
Housing AAA option for 3300 XL 8 mm probe option (A: 16 or A: 28)	Standoff adapter option from original housing (31000 option C) + Probe penetration option from original housing (31000 option D) + 0 2 5. Example Original part number 31000-16-10-15-035-03-02 AAA option for replacement sleeve (015 + 035 + 025) = 075

AAA Option for 31000 Prox Probe Housing	Description
Housing AAA option for 3300 XL NSv probe option (A: 26 or A: 27)	Standoff adapter option from original housing (31000 option C) + Probe penetration option from original housing (31000 option D) + 0 2 6. Example Original part number 31000-27-10-20-035-03-02 AAA option for replacement sleeve (020 + 035 + 026) = 0 8 1 .
Housing AAA option for 3300 XL 11 mm probe option (A: 33 or A: 34)	Standoff Adapter Option from original housing (31000 option C) + Probe penetration option from original housing (31000 option D) + 0 1 7. Example Original part number 31000-33-10-30-113-01-02 AAA option for replacement sleeve (030 + 113 + 017) = 1 6 0 .

Minimum Probe Sleeve Length

3300 XL 8 mm probes	3.5 in (89 mm) = 0 3 5
3300 XL NSv probe	3.6 in (91 mm) = 0 3 6
3300 XL 11 mm probe	2.7 in (69 mm) = 0 2 7

Maximum Probe Sleeve Length

3300 XL 0.5 meter 8 mm probe	18.0 in (457 mm) = 180
3300 XL NSv 0.5 meter probe	18.1 in (460 mm) = 181

3300 XL 0.5 metre 11 mm probe	16.0 in (406 mm) = 160
3300 XL 1.0 meter 8 mm probe	32.5 in (826mm) = 325
3300 XL NSv 1.0 meter probe	32.6 in (828mm) = 326
3300 XL 1.0 meter 11 mm probe	31.7 in (805 mm) = 317

Metric Probe Sleeve for 32000 Proximity Probe Housings 108882-AAA

A: Measured Probe Sleeve Length

	Recommendation
	Order in increments of 1 mm (0.04 in).



The individual probe sleeve length **does not** include the distance from the end of the sleeve to the probe tip or the gap from the probe tip to the target material. If only the part number of the original housing is known, and the sleeve cannot be measured, use the following table to determine the sleeve length:

AAA Option for 32000 Prox Probe Housing	Description
Housing AAA option for 3300 XL 8 mm probe option (A: 16 or A: 28)	Standoff adapter option from original housing (32000 option C) *10 + Probe penetration option from original housing (32000 option D) + 063. Example Original part number 32000-16-10-08-205-03-02 AAA option for replacement sleeve (080 + 205 + 063) = 348

AAA Option for 32000 Prox Probe Housing	Description
Housing AAA option for 3300 XL NSv probe option (A: 26 or A: 27)	Standoff adapter option from original housing (32000 option C) *10 + probe penetration option from original housing (32000 option D) + 066.
	<p>Example</p> <p>Original part number 32000-27-10-10-105-03-02</p> <p>AAA option for replacement sleeve (100 + 105 + 066) = 271.</p>
Housing AAA option for 3300 XL 11 mm probe option (A: 33 or A: 34)	Standoff Adapter Option from original housing (32000 option C) *10 + Probe penetration option from original housing (32000 option D) + 042.
	<p>Example</p> <p>Original part number 32000-33-10-10-105-03-02</p> <p>AAA option for replacement sleeve (100 + 105 + 042) = 247</p>

3300 XL 1.0 meter 8 mm probe	823 mm (32.4 in) = 823
3300 XL NSv 1.0 meter probe	826 mm (32.5 in) = 826
3300 XL 1.0 meter 11 mm probe	802 mm (31.6 in) = 802

Minimum Probe Sleeve Length

3300 XL 8 mm probes	88 mm (3.5 in) = 088
3300 XL NSv probe	91 mm (3.6 in) = 091
3300 XL 11 mm probe	67 mm (2.6 in) = 067

Maximum Probe Sleeve Length

3300 XL 0.5 meter 8 mm probe	457 mm (18.0 in) = 457
3300 XL NSv 0.5 meter probe	460 mm (18.1 in) = 460
3300 XL 0.5 metre 11 mm probe	436 mm (17.2 in) = 436

English Standoff Adaptor 109319-AAA

A: Individual Standoff Adapter Length

Hex	1 3/8 in; threads = 3/4-14 NPT
015	Minimum length 1.5 in (38 mm)
075	Maximum length 7.5 in (191 mm)
Recommendation	Order in increments of 0.5 in (13 mm)

The standoff adapter covers 38 mm (2.0 in) of the probe sleeve **plus** an additional 13 mm (0.5 in).

Therefore, the effective probe penetration length drops to 13 mm (0.5 in).

If you use effective penetration lengths of less than 1.0 inches, signal effects are likely due to probe side view or rear view of metal components.

Metric Standoff Adaptor 109318-AA

A: Individual Standoff Adapter Length

Wrench Flats	35 mm; threads = 3/4-14 NPT
04	Minimum length 40 mm
20	Maximum length 200 mm
Recommendation	Order in increments of 10 mm
Example	120 mm = 12



For desired probe penetration lengths of less than 25 mm (1.0 in), order a separate Individual Standoff Adapter.

The effective probe penetration length will then be reduced by the length of the Individual Standoff Adapter, **plus** an additional 13 mm (0.5 in) due to the NPT thread engagement.

Example:

To create a probe penetration length 13 mm (0.5in), order a 31000 housing with DDD (probe penetration) option of 030 [76 mm (3 in)] and a separate individual standoff adapter that is 51 mm (2.0 in) in length (part number 21003-020).

Spare 3300 XL 8 mm Reverse Mount Probe, 3/8-24 UNF threads

330105-02-12-CC-DD-EE

Spare 3300 XL 8 mm Reverse Mount Probe, M10 X1 threads

330106-05-30-CC-DD-EE

C: Total Length

05	0.5 meter (1.6 feet)
10	1.0 meter (3.3 feet)
15	1.5 meter (4.9 feet)
20	2.0 meters (6.6 feet)
50	5.0 meters (16.4 feet)
90	9.0 meters (29.5 feet)

D: Connector

00	Connector not installed
02	Miniature ClickLoc coaxial connector

E: Agency Approval

00	Not required
05	Multiple approvals

Spare 3300 NSV Reverse Mount Probe, 3/8-24 UNF threads

330906-02-12-CC-DD-EE

Spare 3300 NSV Reverse Mount Probe, M10 X1 threads

330907-05-30-CC-DD-EE

C: Total Length

05	0.5 meter (1.6 feet)
10	1.0 meter (3.3 feet)
50	5.0 meters (16.4 feet)
90	9.0 meters (29.5 feet)

D: Connector

00	Connector not installed
02	Miniature ClickLoc coaxial connector

E: Agency Approval

00	Not required
05	Multiple approvals

Sleeve and Blanking Plugs

104968-01	English Sleeve Plug, threaded, 303 stainless steel
104968-02	Metric Sleeve Plug, threaded, 303 stainless steel.



Plugs fill opening when sleeve is removed from machine case.

104288-01	English Blanking Plug
104288-02	Metric Blanking Plug



Plugs fill extra holes in plastic housing where needed.

Heavy Duty Conduit and Cable Fittings

03813103	Chrome-plated Zinc Conduit Fitting, 3/4-14 NPT
03818100	AISI 316 Stainless Steel Conduit Fitting, 3/4-14 NPT
03818101	AISI 316 Stainless Steel Conduit Fitting, PG21 x M25
03818102	AISI 316 Stainless Steel Conduit Fitting, PG21 x M20
03818103	AISI 316 Stainless Steel Conduit Fitting, PG21 x PG11
03818104	AISI 303 Stainless Steel Cable Gland, PG11
03818105	AISI 316 Stainless Steel Cable Gland, M20
03818111	Nickel-plated Brass Conduit Fitting, PG21 x M20
26650-01	AISI 303 Stainless Steel Reducer, 3/4-14 NPT to 1/2-14 NPT

Graphs and Figures

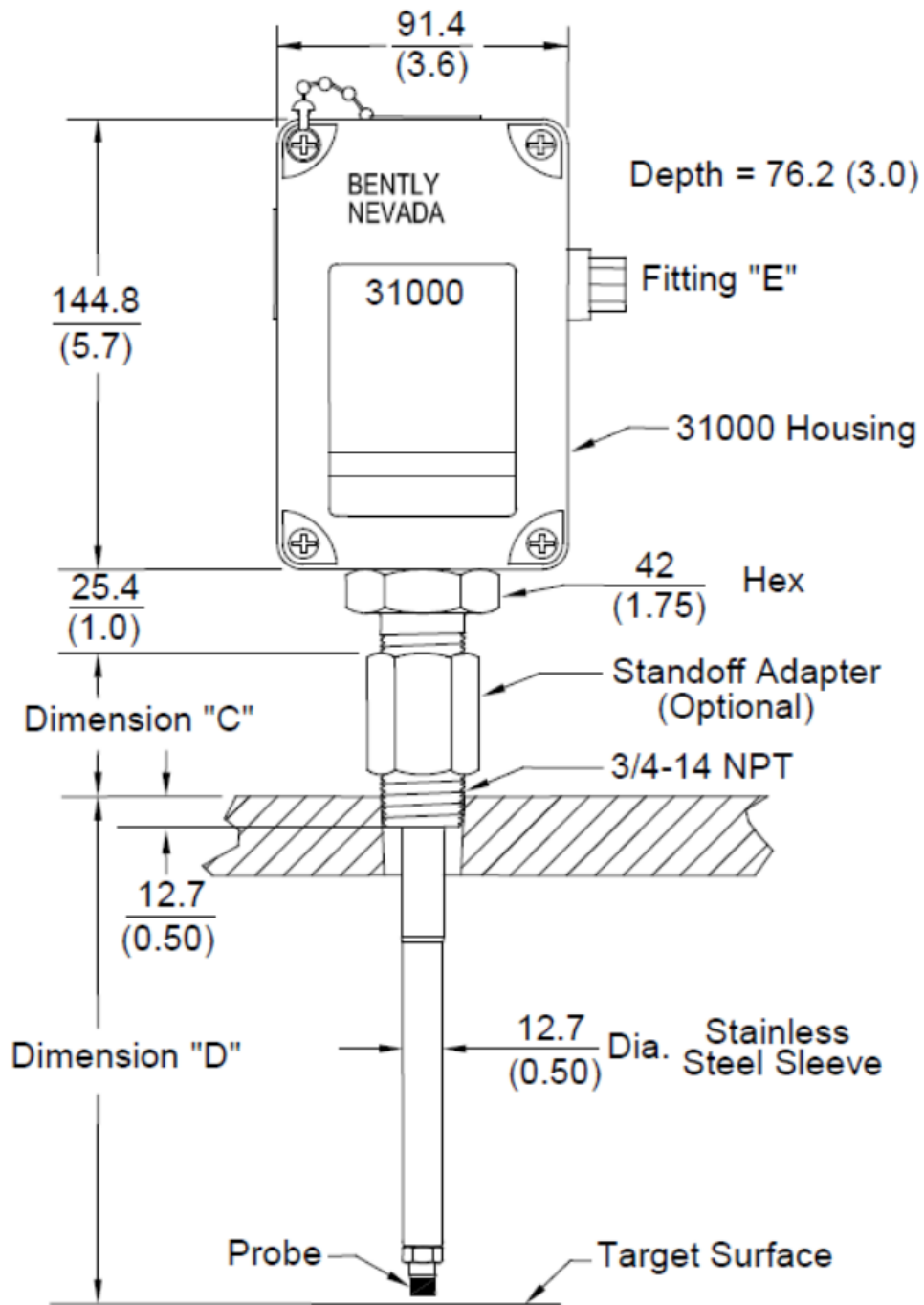
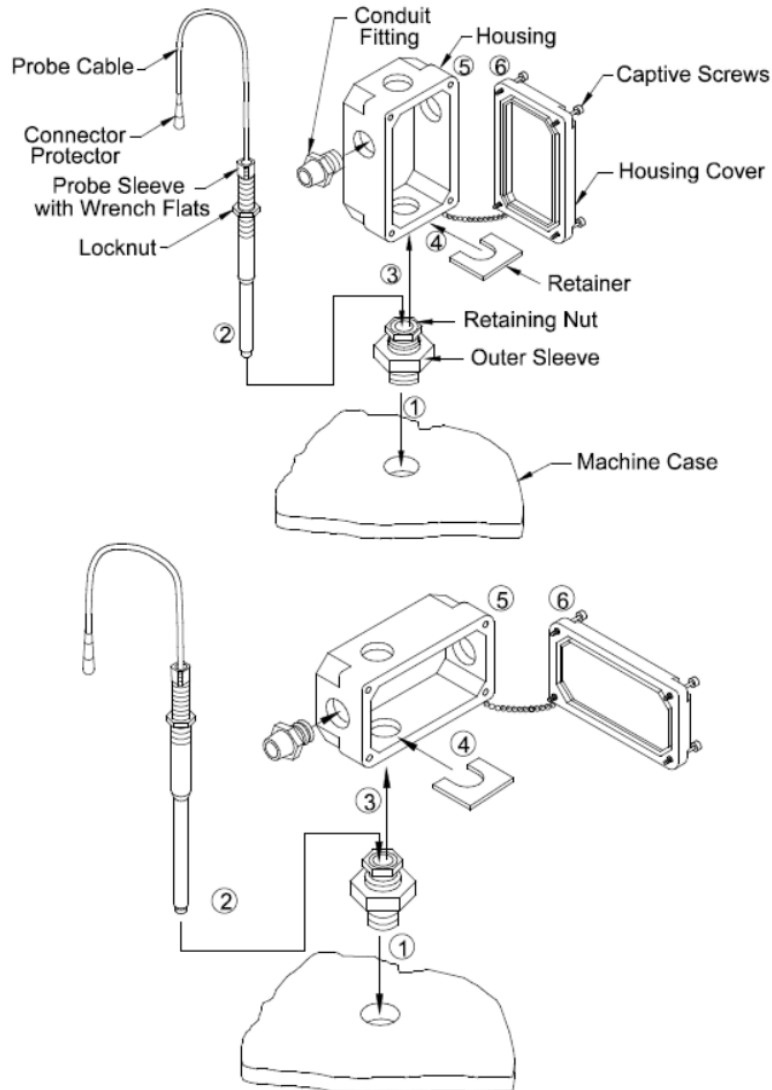

Figure 1: Dimensions for 31000 and 32000 Proximity Probe Housings

Dimensions are in millimeters (inches).

All 4 holes in housing base, 1 per side, will accept sleeve or conduit fittings and cable glands. Fittings are supplied with housing depending on English, metric or DIN type. Hole plugs are provided to seal unused holes.



Installation Procedures

1. Install outer sleeve into machine case.
2. Insert probe sleeve and adjust probe gap.
3. Disconnect probe cable and fit housing over outer sleeve.
4. Slide retainer under retaining nut. Tighten nut.
5. Re-connect probe cable and Connector Protector.
6. Place housing cover on housing and tighten captive screws.
7. If hole plugs are used, tighten hole plug nuts to 0.5 N-m (5 in-lbs).

Figure 2: Vertical and Horizontal Profile Views of the 31000 and 32000 Proximity Probe Housings

Copyright 2022 Baker Hughes Company. All rights reserved.



Bently Nevada, Keyphasor, M2, Proximitor and Orbit Logo are registered trademarks of Bently Nevada, a Baker Hughes business, in the United States and other countries. The Baker Hughes logo is a trademark of Baker Hughes Company. All other product and company names are trademarks of their respective holders. Use of the trademarks does not imply any affiliation with or endorsement by the respective holders.

Baker Hughes provides this information on an "as is" basis for general information purposes. Baker Hughes does not make any representation as to the accuracy or completeness of the information and makes no warranties of any kind, specific, implied or oral, to the fullest extent permissible by law, including those of merchantability and fitness for a particular purpose or use. Baker Hughes hereby disclaims any and all liability for any direct, indirect, consequential or special damages, claims for lost profits, or third party claims arising from the use of the information, whether a claim is asserted in contract, tort, or otherwise. Baker Hughes reserves the right to make changes in specifications and features shown herein, or discontinue the product described at any time without notice or obligation. Contact your Baker Hughes representative for the most current information.

The information contained in this document is the property of Baker Hughes and its affiliates; and is subject to change without prior notice. It is being supplied as a service to our customers and may not be altered or its content repackaged without the express written consent of Baker Hughes. This product or associated products may be covered by one or more patents. See [Bentley.com/legal](https://www.bentley.com/legal).

1631 Bently Parkway South, Minden, Nevada USA 89423
Phone: 1.775.782.3611 (US) or [Bentley.com/support](https://www.bentley.com/support)
[Bentley.com](https://www.bentley.com)